

Symbol

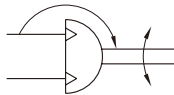

Order example

MCRQ - 20R - [] - []

MODEL TUBE I.D.

ANGLE ADJUSTER
A: With adjusting bolt
R: With shock absorber
 * $\phi 12$ without shock absorber.

PORT LOCATION (*)

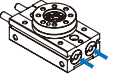
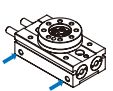
Blank: End port

E: Front port

PORT THREAD
 Blank: M5×0.8 (for $\phi 12, \phi 16$)
 Blank: Rc thread
G: G thread
NPT: NPT thread (for $\phi 20 \sim \phi 40$)

* $\phi 12$ only option.
 * Port location cannot be changed after delivery.

Features

- Centering boss and locating hole for accurate positioning.
- Operating range of table is 0°~190° by angle adjusting screw.
- Compact design using double rack and single pinion.
- Hollow shaft standard for wiring and piping.
- Possible to fit shock absorbers as stops.
- Ease of mounting with integral table.
- Magnetic as standard.

Specification

Model	MCRQ						
Acting type	Double acting						
Tube I.D. (mm)	12	16	20	25	32	40	
Port size	M5×0.8		Rc1/8				
Medium	Air						
Max. operating pressure	adjusting bolt	0.7MPa	1 MPa				
	shock absorber	—	0.6 MPa (*1)				
Min. operating pressure	0.1 MPa (*2)						
Ambient temperature	0~+60°C (No freezing)						
Cushion	adjusting bolt	Rubber bumper					
	shock absorber	—	Shock absorber				
Angle adjustment range	0° to 190°(max.) (*3)						
Sensor switch (*4)	2 wire	RDVE(V): Non-contact					
	3 wire	RNFE(V): NPN, RPFE(V): PNP					
Weight (kg)	adjusting bolt	0.25	0.60	1.24	2.10	4.18	7.67
	shock absorber	—	0.61	1.31	2.12	4.19	7.72
Minimum rotation that will not allow decrease of energy absorption ability	—	72°	58°	69°	77°	82°	

*1. The maximum operating pressure of the actuator is restricted by the maximum allowable thrust of the shock absorber.

*2. No-load conditions.

*3. Be careful if the rotation angle of a type with internal shock absorber is set below the value in the table below, the piston stroke will be smaller than the shock absorber's effective stroke, resulting in decreased energy absorption ability.

*4. RDVE(V) specification, please refer to page 5-11.

Allowable kinetic energy and rotation time adjustment range

Model	Allowable kinetic energy (J)		Rotation time adjustment range for stable operation(s/90°)	
	Adjustment bolt	Internal shock adsorber	Adjustment bolt	Internal shock adsorber
MCRQ-12	0.006	—	0.2 to 1.0	—
MCRQ-16	0.007	0.039		0.2 to 0.7
MCRQ-20	0.048	0.116		
MCRQ-25	0.081	0.294		
MCRQ-32	0.32	1.6	0.2 to 2.0	0.2 to 1.0
MCRQ-40	0.53	2.9	0.2 to 2.5	

* Be careful if a type with internal absorber is used below the minimum speed, the energy absorption ability will decrease drastically.

Torque diagram

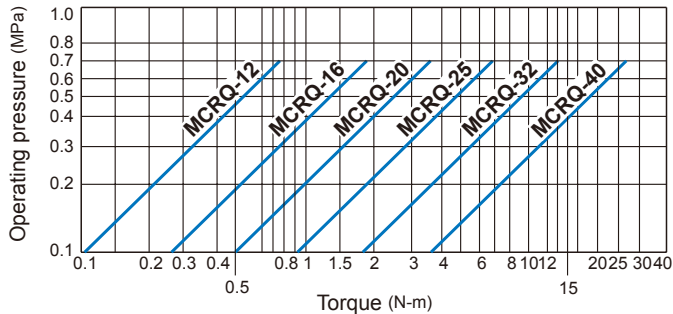

Installation guide of shock absorber

- 1 Install 3 nuts on the shock absorber as the picture shown.
- 2 Bind the A nut and B nut together via tightening them with different rotating direction.
- 3 Hold B nut and rotate C nut to bind the plate and C nut together.
- 4 Unbind the A nut and B nut. The installation is complete.

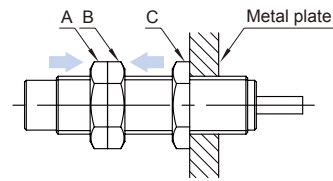

Theoretic force

Unit: N-m

Type		MCRQ					
Tube I.D.		12	16	20	25	32	40
Operating pressure (MPa)	0.1	0.1	0.26	0.5	0.91	1.88	3.78
	0.2	0.21	0.52	1	1.81	3.78	7.53
	0.3	0.31	0.78	1.5	2.72	5.66	11.31
	0.4	0.41	1.04	2.01	3.62	7.56	15.09
	0.5	0.52	1.31	2.51	4.55	9.44	18.87
	0.6	0.63	1.57	3	5.45	11.32	22.62
	0.7	0.73	1.83	3.5	6.36	13.23	26.4

Allowable load

Set the load and moment to be applied to the table within the allowable values shown in the table below. (Values outside of limitations will cause excessive play, deteriorate accuracy, and shorten service life.)

Pictures	Allowable radial load (N)		Allowable thrust load (N)		Allowable moment (N.m)
	12	16	(a)	(b)	
			20	25	
	54	78	197	363	1.5
			71	71	
			74	78	
					2.4
					5.3
					9.7
					18
					25

Rotating direction and angle

- When the port 1 is pressurized, the flange rotates in clockwise (CW) direction.
- When the port 2 is pressurized, the flange rotates in counter-clockwise (CCW) direction.

The rotating angle range can be adjust by the method shown as right figure.

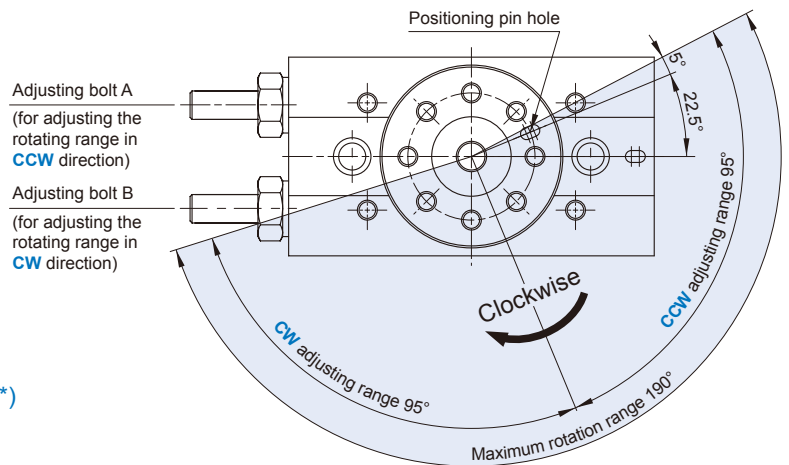
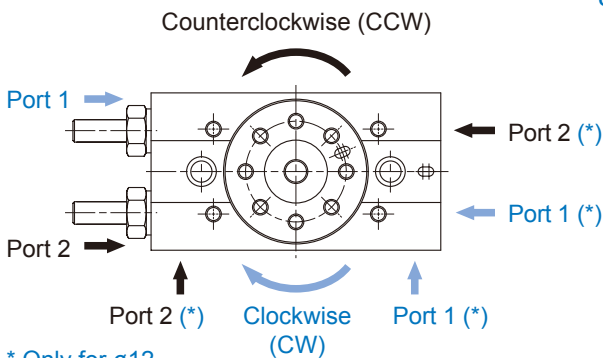

NOTE

- The figure shows the rotating range and use the pin hole as indicator.
- The pin hole position in the figure locates at the situation which the CCW & CW rotating range are both adjusted at 90°.

Rotating range adjusting example

- The followed figures show the rotating range of different adjustment via bolt A and B. (The drawings also show the rotation ranges of the positioning pin hole.)

190° (Max) Rotation

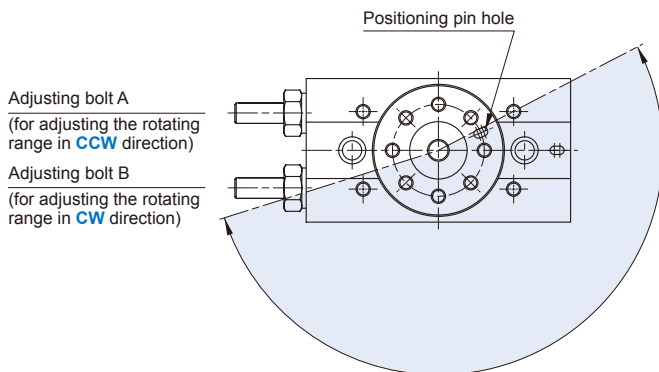

180° Rotation

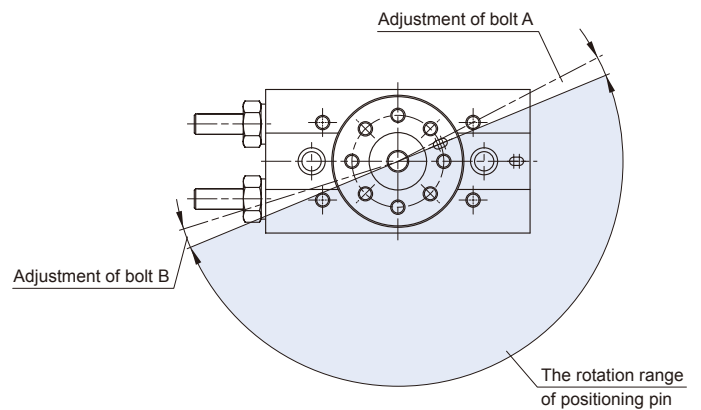

90° Rotation

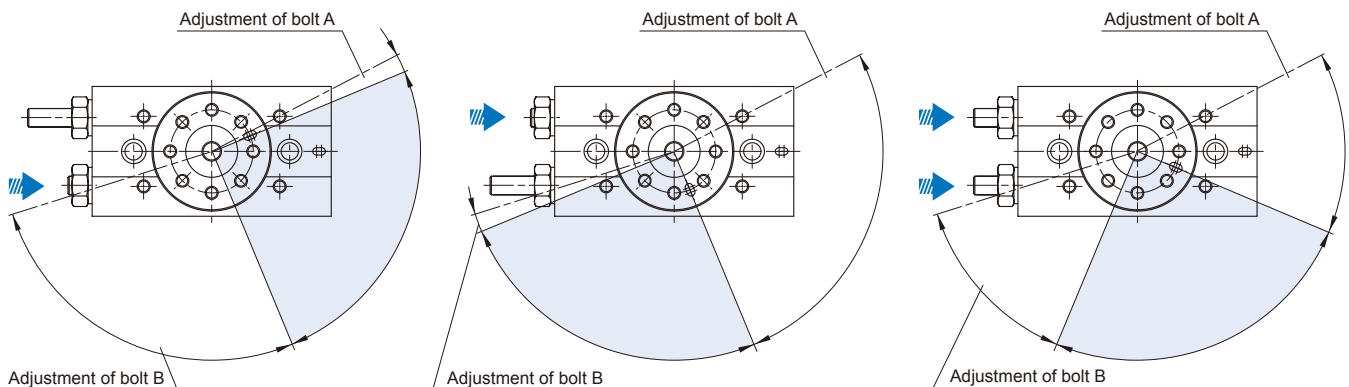

ROTARY ACTUATOR

ø16~ø32

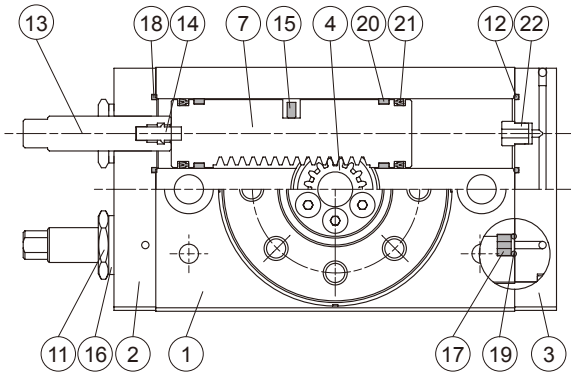

ø40

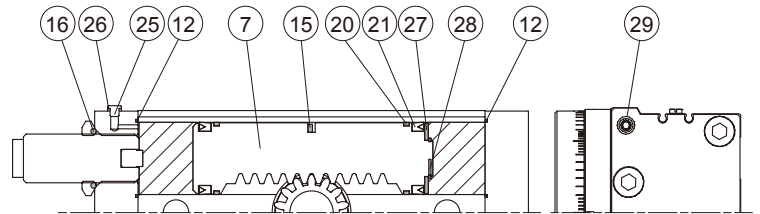

ø12

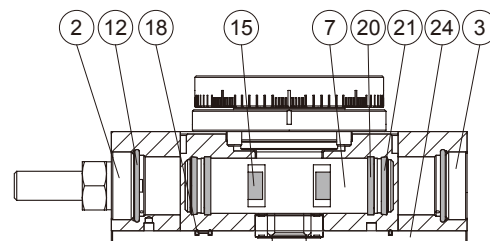
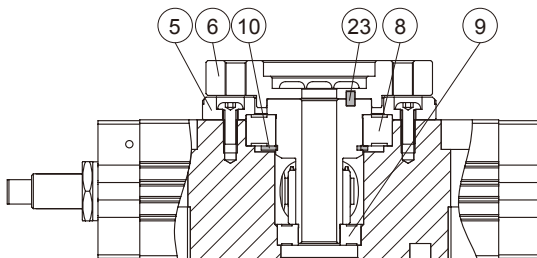

Material

No.	Part name	Material	Tube I.D. & Q'y			Repair kits (inclusion)
			12	16	20~32	
1	Body	Aluminum alloy	1			
2	Cover	Aluminum alloy	2	1		
3	End cover	Aluminum alloy	2	1		
4	Pinion	SCM	1			
5	Bearing retainer	Aluminum alloy	1			
6	Table	Aluminum alloy	1			
7	Piston	Stainless steel	2			
8	Rolling bearing	Bearing steel	1			
9	Rolling bearing	Bearing steel	1			
10	Snap ring	Spring steel		1	-	
11	Seal nut	Carbon steel	2			
12	O-ring	NBR	4	2	4	●
13	Adjusting bolt *1	Stainless steel *2	2			
	Shock absorber	-	-	2		
14	Cushion pad *1	NBR	2			
15	Magnet	Magnet material	4	2		
16	Seal washer	*3	2			●
17	Fixed	Copper	-	4	2	-
18	Piston packing	NBR	1	-	2	-
19	O-ring	NBR	-	4	2	-

No.	Part name	Material	Tube I.D. & Q'y				Repair kits (inclusion)
			12	16	20~32	40	
20	Wear ring	Complex resin	4				
21	Piston Seal	NBR	4				●
22	Stop chunk	Aluminum alloy	-	2	-		
23	Pin *4	SCM	1				
24	Plate	Aluminum alloy	1	-			
25	Plug	Copper	-	1			
26	Plug washer	PET	-	1			
27	Piston retainer	Aluminum alloy	-	2			
28	Piston snap ring	Spring steel	-	2			
29	Plug	Carbon steel	-	2			

*4. ø20~ø40: Key

Order example of repair kits

Tube I.D.	Repair kits
ø12	PS-MCRQ-12
ø16	PS-MCRQ-16
ø20	PS-MCRQ-20
ø25	PS-MCRQ-25
ø32	PS-MCRQ-32
ø40	PS-MCRQ-40

*1. Only for (A) with adjusting bolt. *2. ø40: Carbon steel
 *3. ø12~ø32: NBR+Carbon steel; ø40: NBR

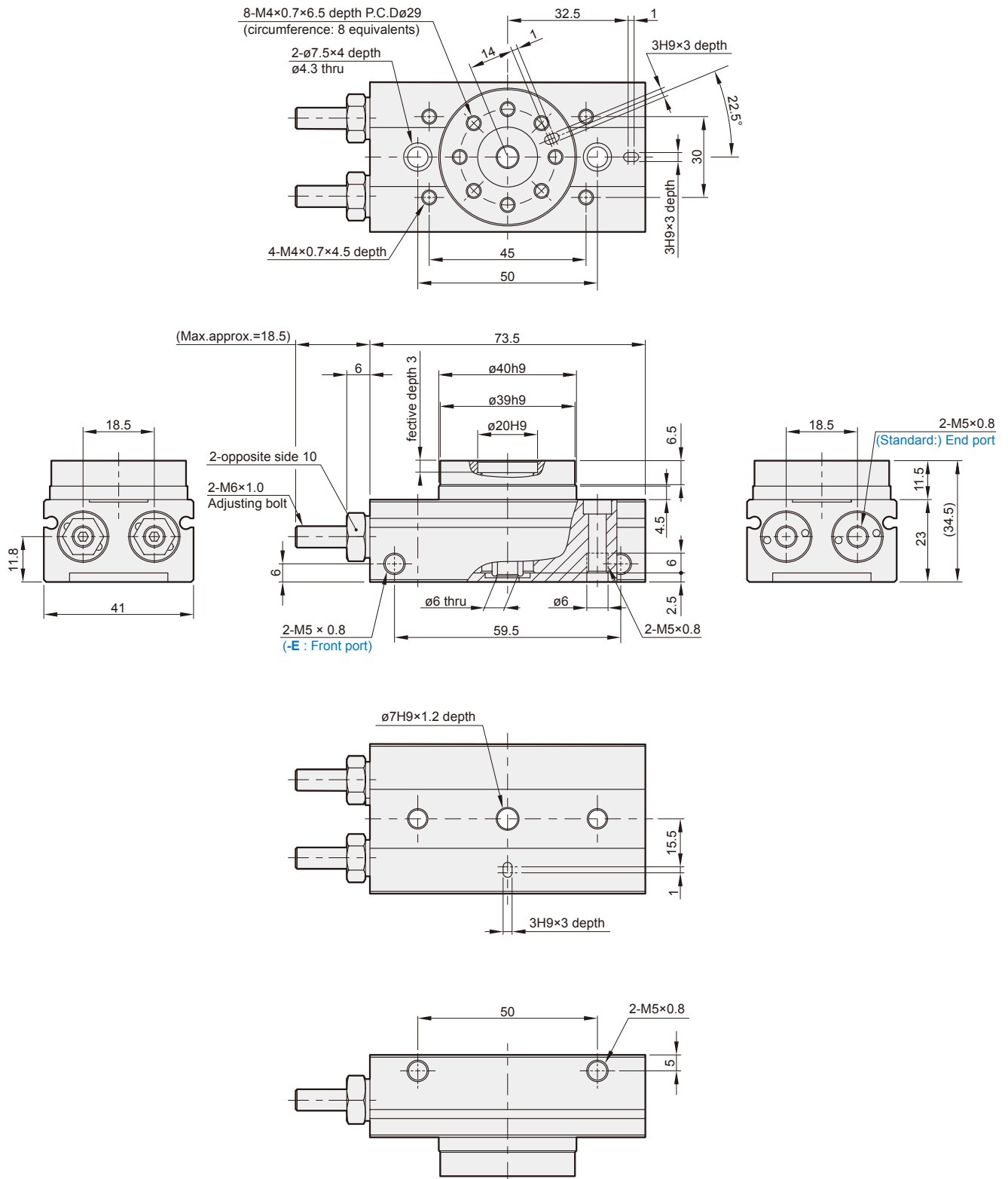

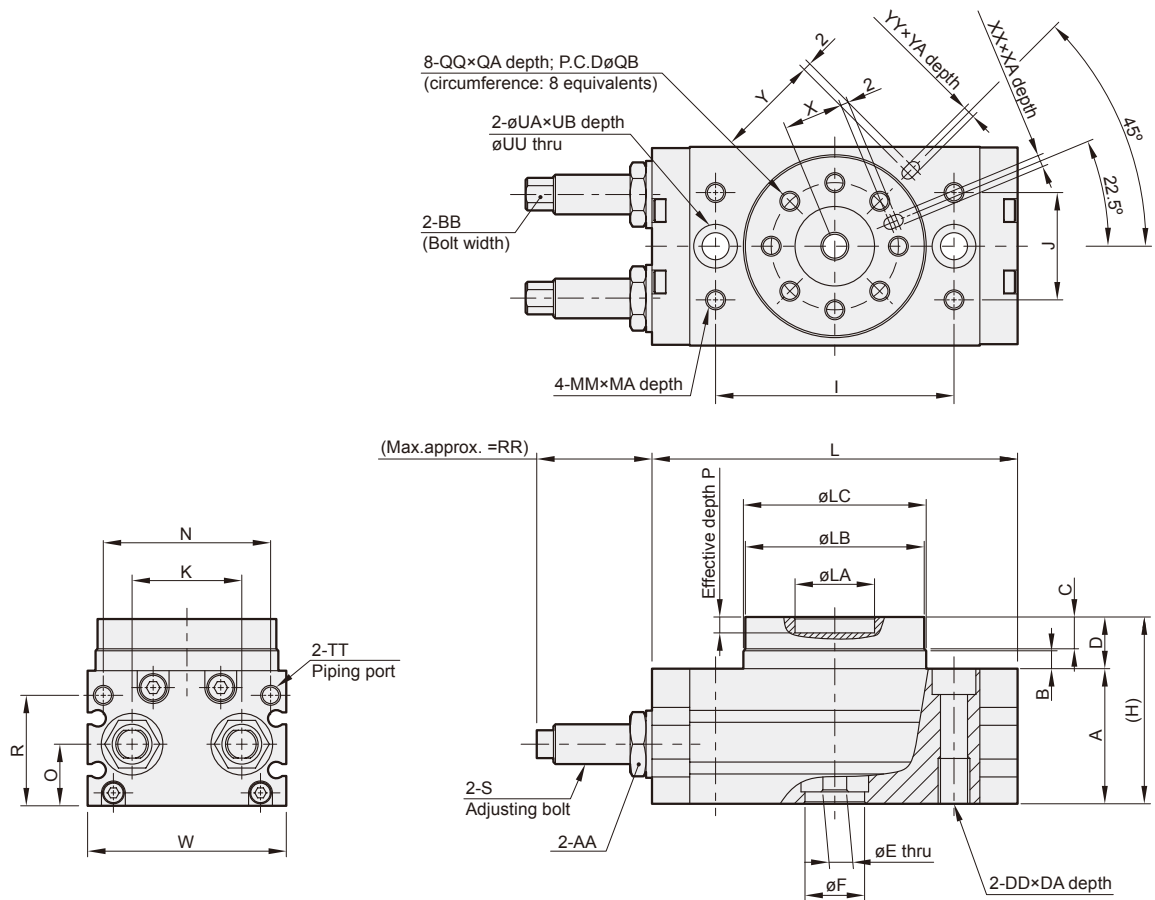

MCRQ-16~25R

With shock absorber

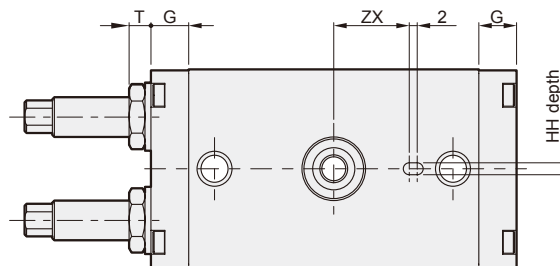
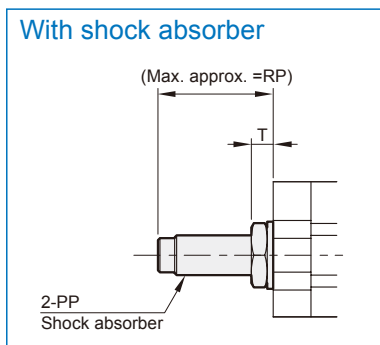

Unit: mm

Code Tubr I.D.	A	AA	B	BB	C	D	DA	DD	E	F	G	H	HH	I	J	K	L	LA	LB	LC	MA	MM	N
16	34	14	4.5	7	8	13	12	M8×1.25	6	15H9	9.5	47	3H9×3.5	60	27	26	92	20H9	45h9	46h9	8	M5×0.8	37
20	40	17	6.5	7	10	17	15	M10×1.5	10	22H9	12	57	4H9×4.5	84	37	32	127	32H9	65h9	67h9	8	M6×1	54
25	46	22	7.5	8	12	20	18	M12×1.75	13	26H9	15.5	66	5H9×5.5	100	50	37	152	35H9	75h9	77h9	8	M8×1.25	63

Code Tubr I.D.	O	P	PP	QA	QB	QQ	R	RP	RR	S	T	TT	UA	UB	UU	W	X	XA	XX	Y	YA	YY	ZX
16	15.5	4	FK-1008L-S	8	32	M5×0.8	29	29	31	M10×1.0	5.5	M5×0.8	11	6.5	6.8	50	15	3.5	3H9	27	3.5	3H9	19
20	19.5	4.5	FK-1008L-S	10	48	M6×1.0	33	23.5	26	M10×1.0	4.5	Rc1/8	14	8.5	8.6	70	23	4.5	4H9	39	4.5	4H9	28
25	22	5	FK-1412L-S	12	55	M8×1.25	37.5	33	31.2	M14×1.5	7.5	Rc1/8	18	10.5	10.5	80	26.5	5.5	5H9	45	5.5	5H9	33

ROTARY ACTUATOR

MCRQ-32R, 40R

With shock absorber

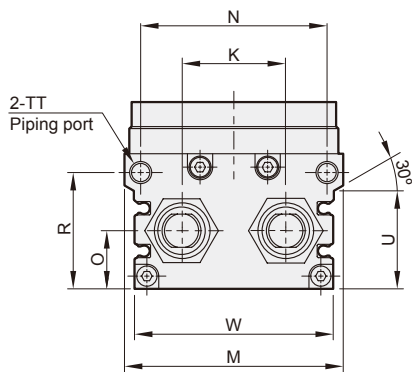
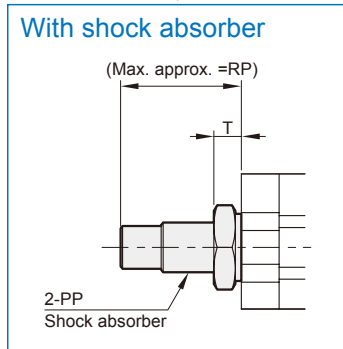

MCRQ-40

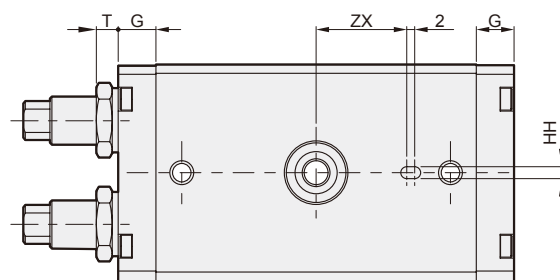
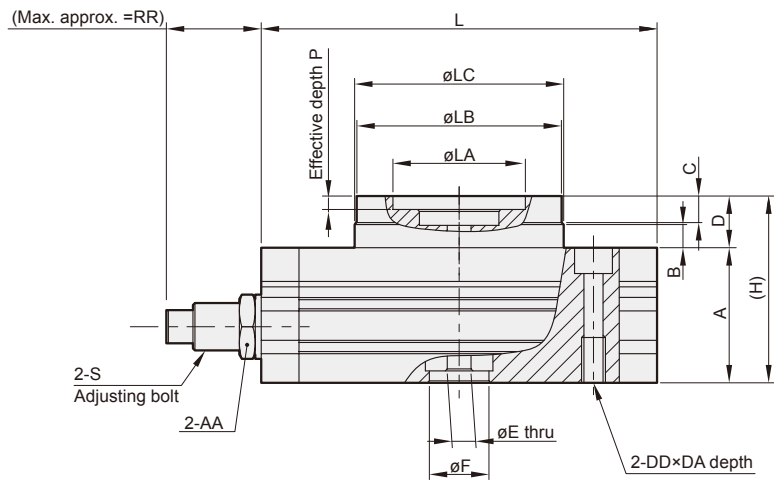
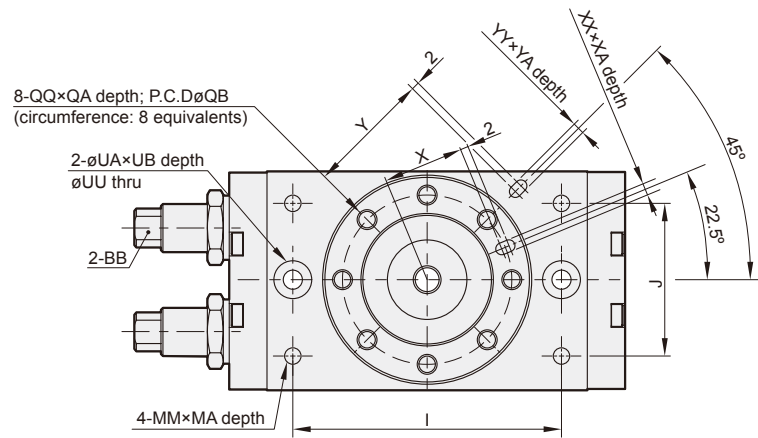
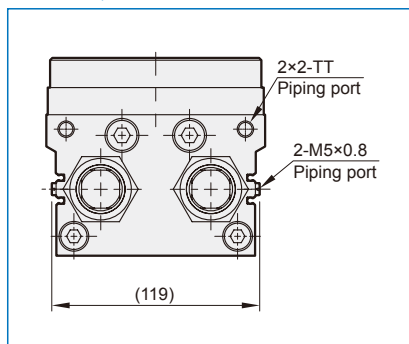

Unit: mm

Code Tubr I.D.	A	AA	B	BB	C	D	DA	DD	E	F	G	H	HH	I	J	K	L	LA	LB	LC	M	MA
32	59	30	12	Bolt width 12	14.5	27	18	M12x1.75	13	24H9	17	86	6H9x4.5 dp	130	66	47	189	56H9	98h9	100h9	102	10
40	74	36	15	Bolt width 21	16.5	32	25	M16x2.0	24	32H9	24	106	8H9x6.5 dp	150	80	60	240	64H9	116h9	118h9	120	13

Code Tubr I.D.	MM	N	O	P	PP	QA	QB	QQ	R	RP	RR	S	T	TT	U	UA	UB	UU	W	X	XA
32	M8x1.25	85	27.5	6	FK-2016L-S	14.5	77	M10x1.5	50.5	46	38.1	M20x1.5	10.5	Rc1/8	42	18	10.5	10.5	95	37.5	6.5
40	M12x1.75	100	37	9	FK-2725L-S	16.5	90	M12x1.75	65.5	68	45	M27x1.5	7	Rc1/8	57	20	12.5	14.2	113	44	8.5

Code Tubr I.D.	XX	Y	YA	YY	ZX
32	6H9	59	4.5	6H9	49
40	8H9	69	4.5	8H9	54