



Features

- Available with comprehensive range of Tube I.D. 12 ~ 32mm.
- Highly accurate air driven device for holding work-piece.
- Magnetic as standard.

Specification

Model		MCHB				
Acting Type		Double / Single acting				
Tube I.D. (mm)		12	16	20	25	32
Port size		M3×0.5	M5×0.8			
Medium		Air				
Operating pressure range	Double acting	0.15~0.7 MPa				
	Single acting	0.2~0.7 MPa				
Ambient temperature		-5~+60°C (No freezing)				
Max. operating frequency (c.p.m)		180				
Lubrication	Cylinder	Not required				
	Lever	Grease (Actuation at)				
Max. arm length (L) (mm)		30	40	60	70	85
Lever open / close stroke		6	8	12	14	16
Sensor switch (*)		RDE, RDE-D: Non-contact				
Weight (g)	Double acting	66	144	255	419	719
	Single acting	66.5	145	257	422	722

Order example

MCHB — 16 — S

MODEL

TUBE I.D.

ACTING

12

16

20

25

32

Blank: Double acting
S: Single acting
(Normally open)

* RDE, RDE-D specification, please refer to page 5-6.

Length of gripping point

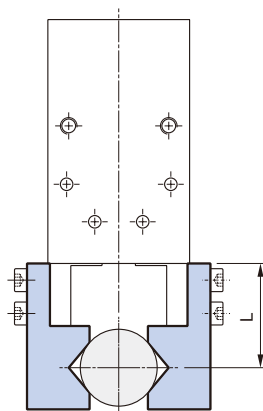

Installation of sensor switch

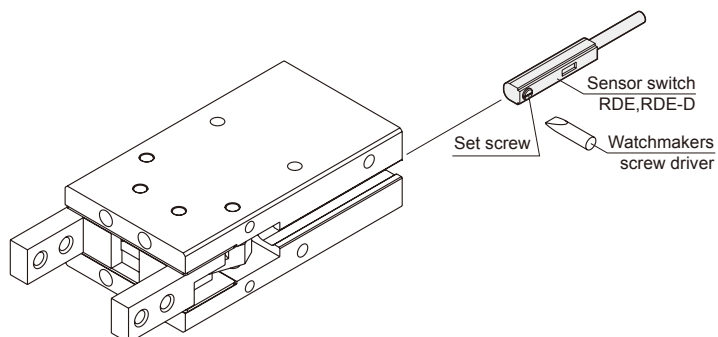

Double acting

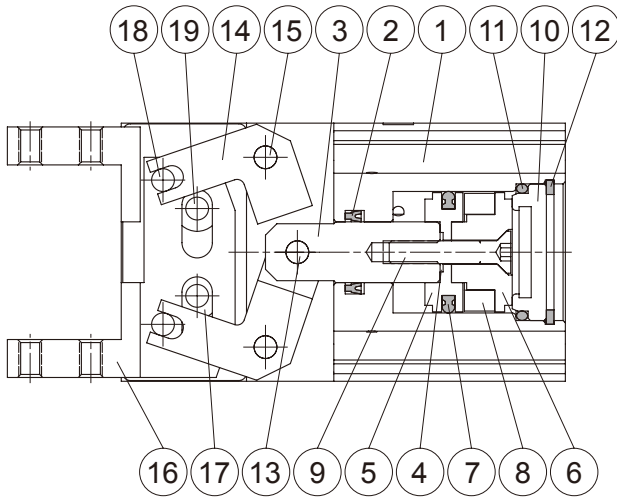

Single acting

Normally open

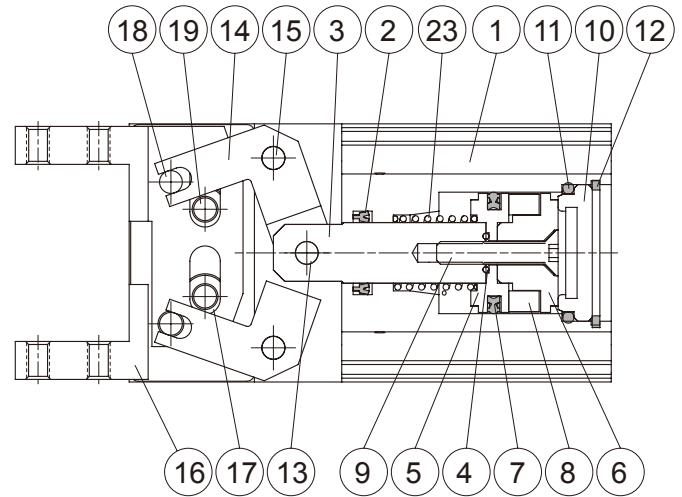

Material

No.	Part name	Material	Q'y	Repair kits (inclusion)
1	Body	Aluminum alloy	1	
2	Rod packing	NBR	1	●
3	Piston rod	Stainless steel	1	
4	Gasket	NBR	1	●
5	Piston-R	Aluminum alloy	1	
6	Piston-H	Aluminum alloy	1	
7	Piston packing	NBR	1	●
8	Magnet ring	Magnet material	1	
9	Screw	Stainless steel	1	
10	Head cover	Carbon steel	1	
11	Cover ring	NBR	1	●
12	Stop ring	Spring steel	1	
13	Spindle river	Bearing steel	1	
14	Grip per	Carbon steel	2	
15	Grip rivet	Carbon steel	2	
16	Grip per	Carbon steel	2	
17	Bush	Stainless steel	4	
18	Grip rivet	Bearing steel	2	
19	Grip rivet	Carbon steel	2	
20	Screw	SCM	4	
21	Screw	SCM	4	
22	Washer for grip	Stainless steel	2	
23	Spring	Spring steel	1	

Order example of repair kits

Tube I.D.	Repair kits
ø12	PS-MCHB-12
ø16	PS-MCHB-16
ø20	PS-MCHB-20
ø25	PS-MCHB-25
ø32	PS-MCHB-32

Effective gripping force (Double acting)

Indication of effective force.

The effective gripping force shown in the graphs to the right is expressed as F, which is the thrust of one finger, when both fingers and attachments are in full contact with the workpiece as shown in the figure below.

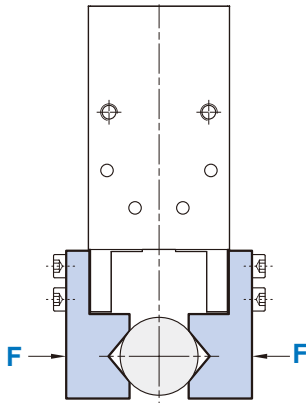

$1\text{N} = 0.102 \text{ kgf}$
 $1\text{MPa} = 10.2 \text{ kgf/cm}^2$

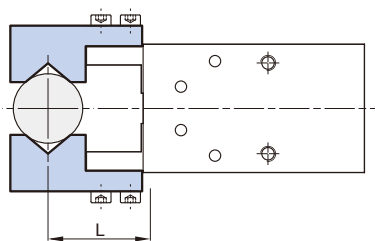

External grip

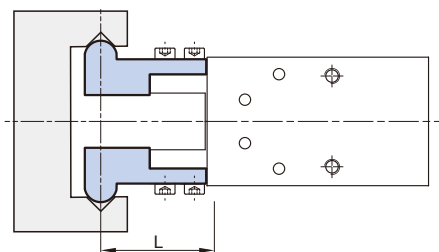

Internal grip

External gripping force Double acting

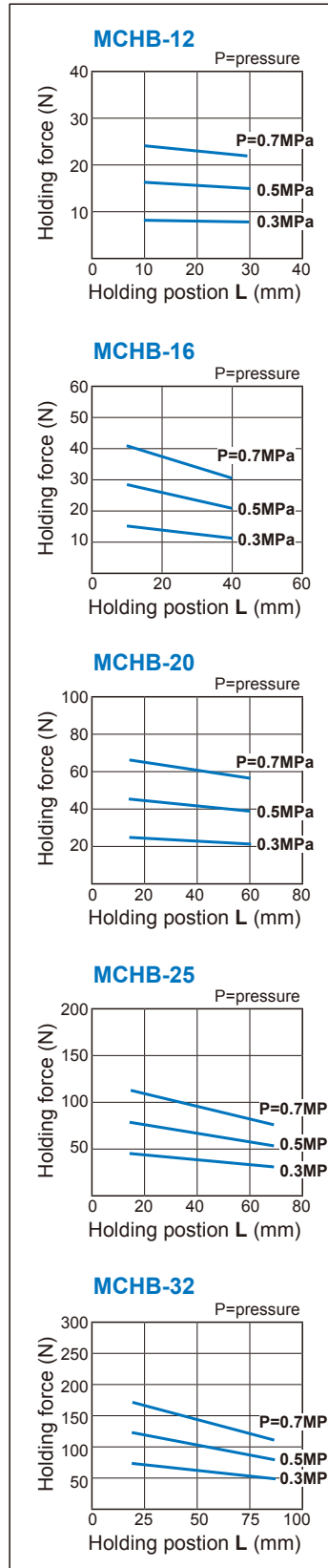

Internal gripping force Double acting

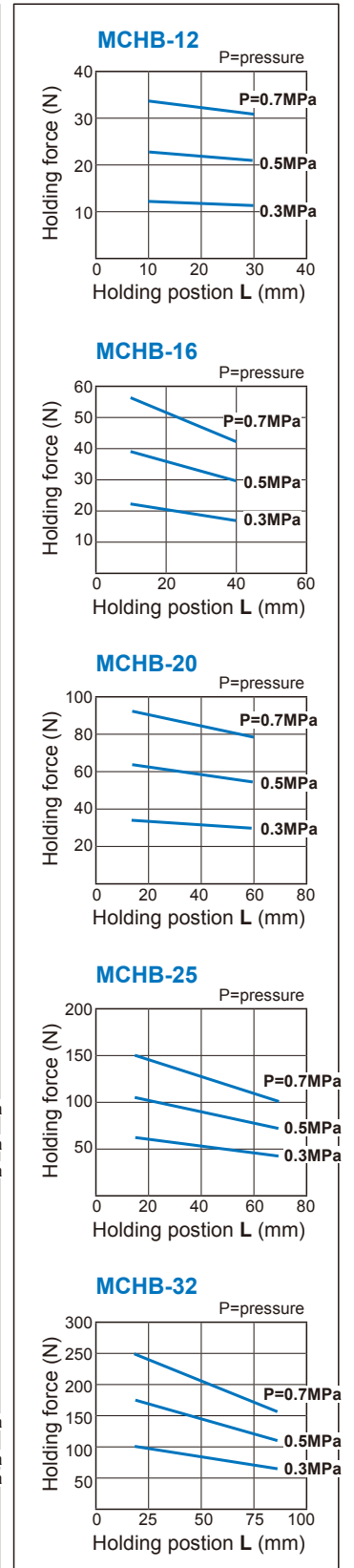

Effective gripping force (Single acting)

Indication of effective force.

The effective gripping force shown in the graphs to the right is expressed as F, which is the thrust of one finger, when both fingers and attachments are in full contact with the workpiece as shown in the figure below.

1N=0.102 kgf
1MPa=10.2 kgf/cm²

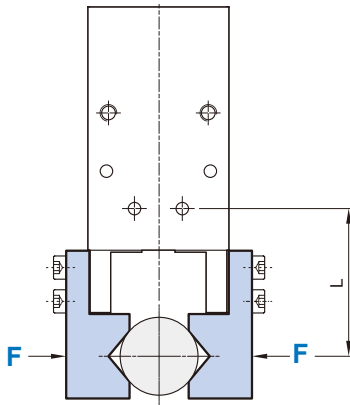

External grip
(Single acting / Normally open)

External gripping force Single acting / N.O.

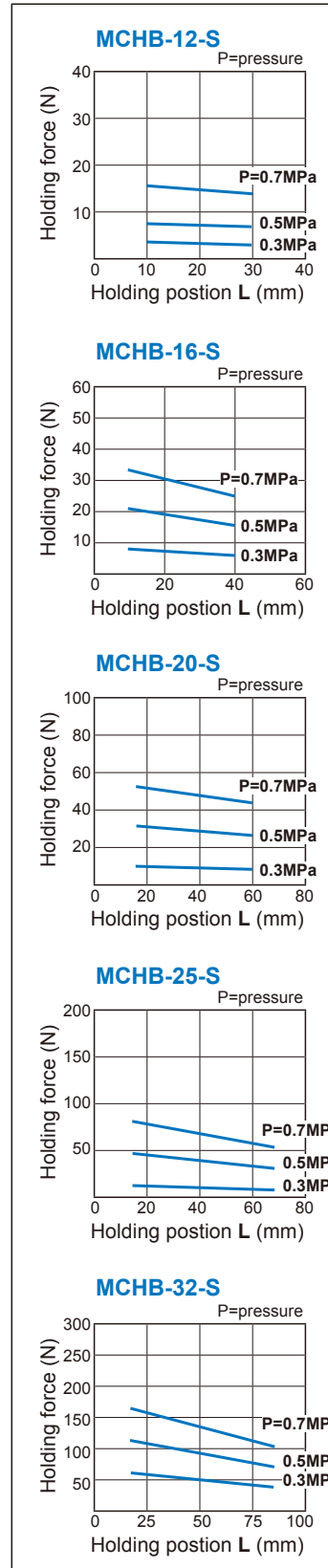

PARALLEL GRIPPER (2-Finger)

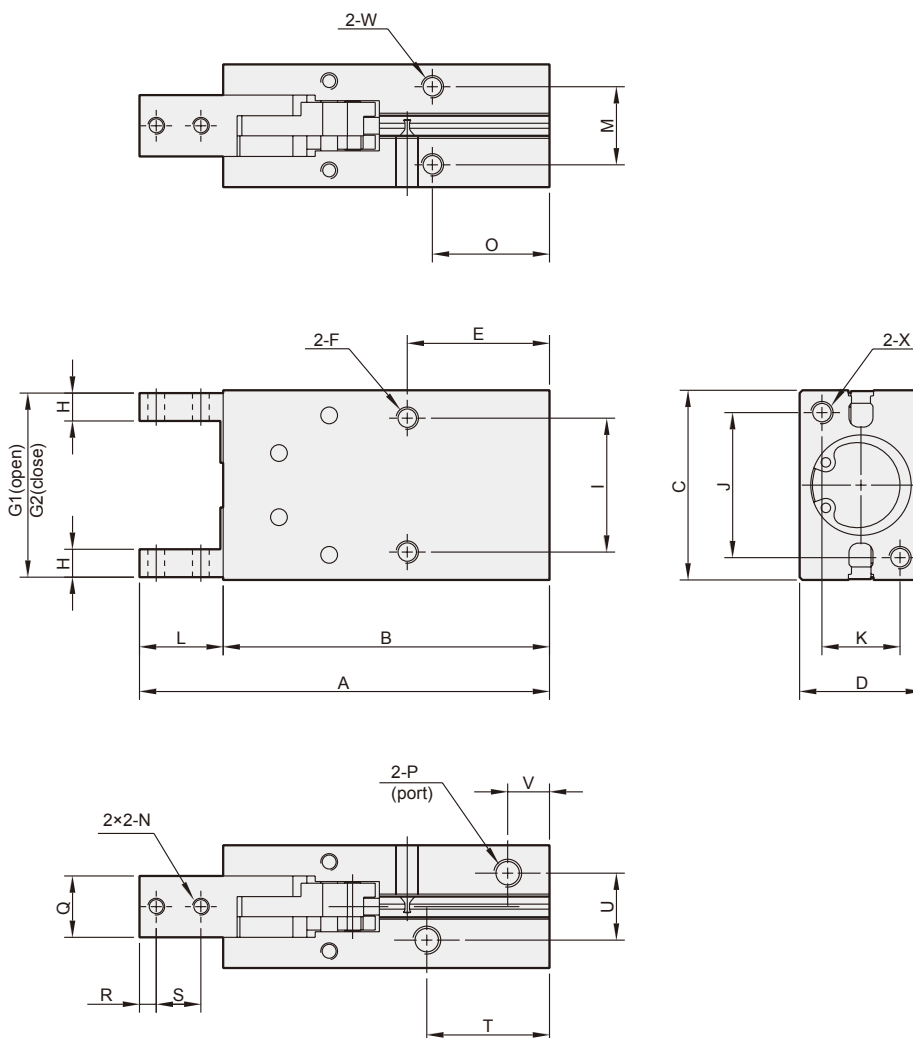

Code Tube I.D.	A	B	C	D	E	F	G1	G2	H	I	J	K	L	M	N	O
12	63.5 (68.5)	50.5 (55.5)	28	16	20 (25)	M3×0.5×5 depth	27	21	4	18	17	10	13	10	M3×0.5	16 (21)
16	73.5 (78.5)	58.5 (63.5)	34	22	25.5 (30.5)	M4×0.7×11 depth	33	25	5	24	26	14	15	14	M3×0.5	21 (26)
20	88.5 (93.5)	69.5 (74.5)	45	26	25 (30)	M5×0.8×8 depth	44	32	6	30	35	16	19	16	M4×0.7	19 (24)
25	102.5 (107.5)	78.5 (83.5)	52	32	28 (33)	M6×1.0×10 depth	51	37	8	36	40	20	24	20	M5×0.8	22 (27)
32	120.5 (125.5)	90.5 (95.5)	60	40	34 (39)	M6×1.0×10 depth	59	43	10	44	46	24	30	26	M6×1.0	26 (31)

Code Tube I.D.	P	Q	R	S	T	U	V	W	X
12	M3×0.5×5 depth	7	3	6	23	10.2	7.5	M3×0.5×5 depth	M3×0.5×5 depth
16	M5×0.8×5 depth	11	3	8	22	12	7.5	M4×0.7×7 depth	M4×0.7×7 depth
20	M5×0.8×5 depth	12	4	10	26	13	8	M5×0.8×8 depth	M5×0.8×8 depth
25	M5×0.8×5 depth	14	5	12	29	18	8.5	M6×1.0×10 depth	M6×1.0×10 depth
32	M5×0.8×5 depth	20	7	15	35	24	10.5	M6×1.0×10 depth	M6×1.0×10 depth

* Values in () are for single acting.